

**SEEPEX.**

An Ingersoll Rand Business

**TO EXACTING STANDARDS**  
**PRODUCT GROUP N**  
**BNA RANGE, API 676**

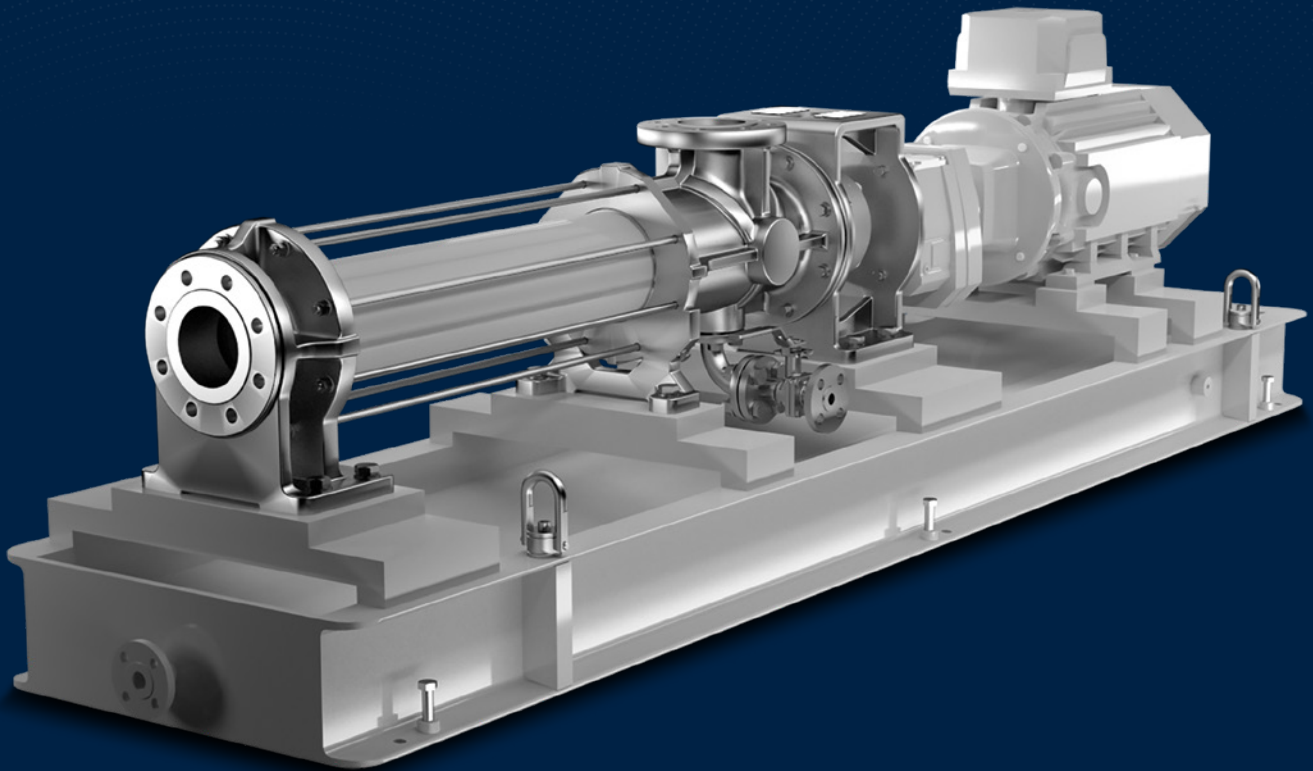

**BNA**

# API COMPLIANT.

SEPEX progressive cavity pumps from the BNA range are designed to fulfill the exacting requirements of the Oil & Gas Industry and meet American Petroleum Institute (API) standards.

BNA range pumps have rugged, heavy-duty castings in accordance with API 676 and casing parts made of super duplex stainless steel.

The maximum containment pressure for both suction and discharge is 50 bar. The flanges are according to ASME B16.5 – suitable for two times the external forces and moments required by API 676.

Additionally, SEPEX offers fully API 682 compliant mechanical seals with optimized seal plans. ASTM materials, full traceability and compliance with NACE MR0175 are standard features. The pump can also be designed for gas hazardous areas.

# WHY A SEPEX API PUMP?

## BENEFITS

- All process parts are cast or machined – no welding required
- Reduced number of documents and fewer inspections
- API compliant
- Heavy duty design
- Standardized pump components
- Favorable lead time

## OPTIONAL

- Casing items available with NORSOK qualification
- Motors acc. to IEEE841/NEMA
- Seal plans optimized for use with a progressive cavity pump
- Dry-running protection device
- Supply of pressure limiting valve acc. to API 520 & API 526

## KEY FACTS

- Conveying capacity: 0.1–150 m<sup>3</sup>/h (0.44–660 USGPM)
- Working pressure (MAWP): up to 48 bar (700 psi)
- Casing pressure (MACP): up to 50 bar (725 psi)

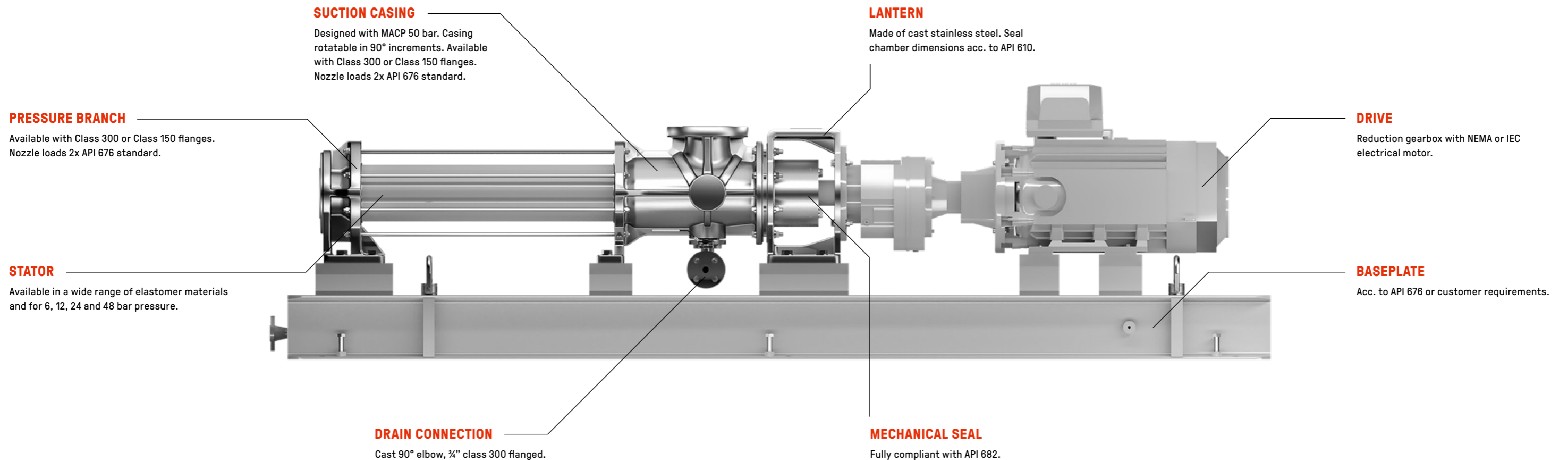

# SEEPEX.

An Ingersoll Rand Business

**SEEPEX GmbH**  
[www.seepex.com](http://www.seepex.com)