

**SEEPEX.**  
ALL THINGS FLOW

# THE BIG MINIMIZER PRODUCT GROUP M



# CUT AND CHOP.

SEEPEx macerators cut and chop entrained solids and fibrous materials so they can be pumped without clogging pipes or damaging pumps and other process equipment. This minimizes downtime, improves safety records, minimizes repair costs and reduces operating costs. Our macerators work in municipal and industrial wastewater sectors as well as in selected process applications.

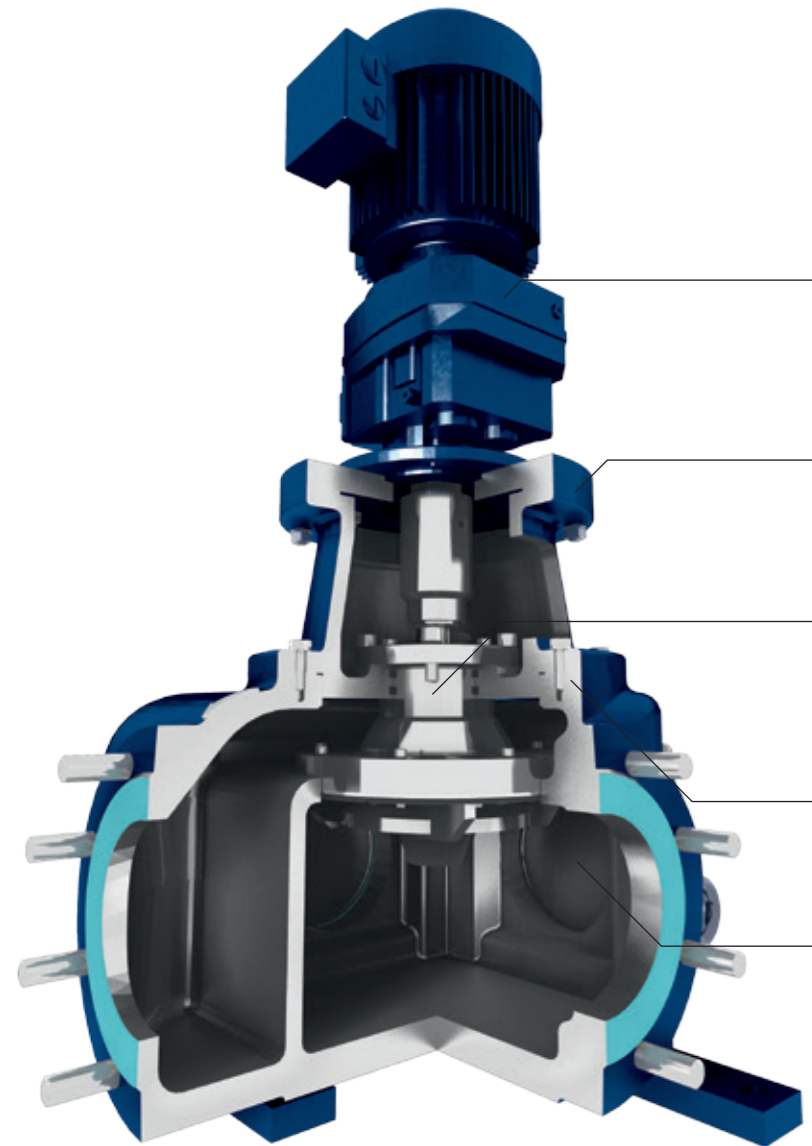

### DRIVE

Fixed or variable speed drives can be fitted. Operates at low speeds resulting in high torque and low power consumption.

### LANTERN

For connection of macerator housing and drive, and the cutting "headstock" assembly.

### HEADSTOCK ASSEMBLY

Easy replacement of the complete unit as a cartridge. Includes components for maceration through cutting instead of tearing and crushing.

### CUTTER CASING

Product feed is possible from three different directions.

### CLEANOUTS

Spacious design for quick cleaning and draining.

# REPLACEABLE HEADSTOCK ASSEMBLY

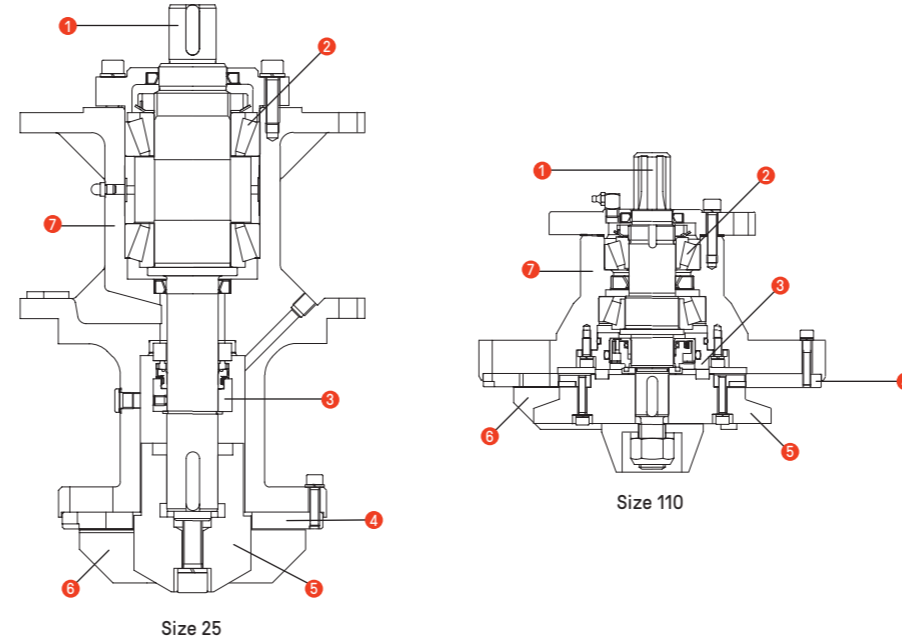

### 1 INPUT SHAFT

For quick separation or connection of drive and headstock assembly.

### 2 BEARING

Large tapered roller bearings, for heavy loads, can be re-lubricated externally.

### 3 SHAFT SEAL

Mechanical seal that operates in a closed chamber and includes a flushing connection (size 110 only as an option).

### 4 SHEAR PLATE

Highly wear-resistant, hardened tool steel with holes of different shape, size and number. A knife head rotates on a stationary shear plate and macerates solids entrained in the conveyed product using a cutting action. Various shear plate designs to optimize particle size reduction are optionally available. The size, shape and number of holes/slots determines the particle size and flow rate. 10 standard designs and further customized designs are available.

Examples:

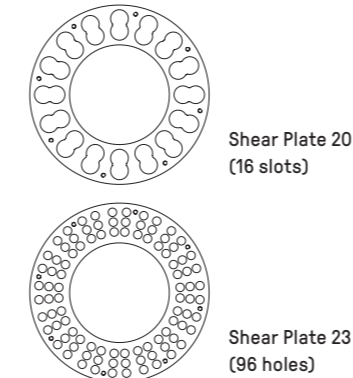

### 5 CUTTER HEAD

Available with different numbers of tungsten carbide knives.

### 6 KNIVES

Made of hard tungsten carbide. They are fixed on the headstock at an inclined angle, resulting in a cutting/slicing action in conjunction with the shear plate.

### 7 BEARING HOUSING

For containment of drive shaft with cutter head, bearing, seal and shear plate. This unit allows the exchange of the complete headstock assembly.

# OVERVIEW OF RANGES

### I RANGE, INLINE DESIGN

The GG-25 cast grey iron integral solids separator is unique to the I range. It is installed in horizontal pipe work and directly connected to a SEEPEx pump or in a compact pipeline. Product feed is possible from three different directions. Two sizes are available.

At ~5% solids, size 25 is suitable for flow rates up to 30 m<sup>3</sup>/h (132 USGPM) and size 110 can handle flows up to 150 m<sup>3</sup>/h (660 USGPM).

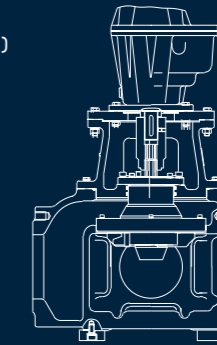

### U RANGE, UNIVERSAL DESIGN WITH OPTIONAL SOLIDS SEPARATOR

Installation either on a vertical pipeline or supply tank with direct connection to a SEEPEx pump. The U range is uniquely available in stainless steel construction and can be used in corrosive or food processing applications. Two sizes are available.

At ~5% solids, size 25 is suitable for flow rates up to 30 m<sup>3</sup>/h (132 USGPM) and size 110 can handle flows up to 150 m<sup>3</sup>/h (660 USGPM).

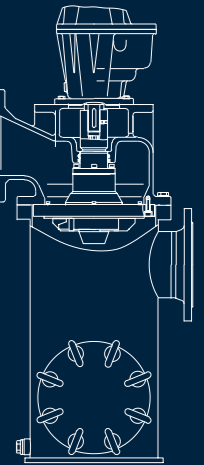

# DRIVING POWER

The driving power indicated for sizes 25 and 110 refers to sludges with a DS content of 5%. For higher solids content, the maximum flow rate must be reduced and the driving power has to be increased. Driving power for other applications must be advised upon individual request.

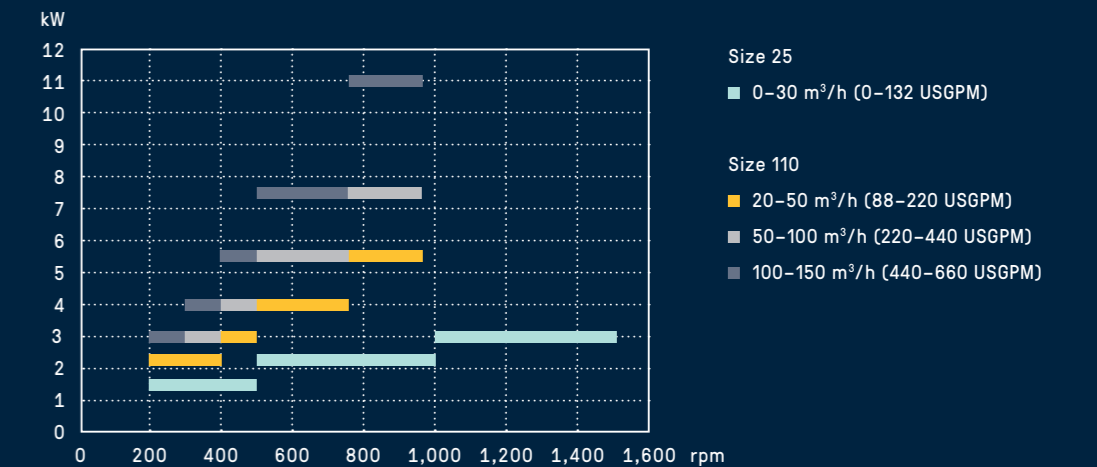

## APPLICATIONS

SEEPEX macerators cut and chop almost any solid or fibrous materials in pumped fluids. They improve the reliability and life of both SEEPEX pumps and other process devices like centrifuges and filter presses. The degree of size reduction will vary depending on flow rate, speed and shear plate design. These parameters can be adapted to suit individual needs. SEEPEX macerators are used for applications in agriculture, construction, dye and paint production, environmental waste, food and beverages, fish processing, petrochemicals, pulp and paper, shipbuilding, sugar refining, biogas and waste disposal.

### FEATURES

- Controlled macerating due to variable output speeds and shear plates with different-sized openings
- Easy maintenance due to simple replacement of the entire cutter head cartridge
- Simplified construction with a single shaft, seal and bearing set
- Lower energy consumption compared to alternative macerating technologies
- Can cut plastic, hair and fibers that pass through twin shaft designs
- Two ranges with two sizes in each

### KEY FACTS

- Flow rate:  
2–150 m<sup>3</sup>/h (8.8–660 USGPM)

**SEEPEX GmbH**

[www.seepex.com](http://www.seepex.com)